



# Form Mould Services cc.

Phone: (011)953-3947/59  
 Fax: (011)953-4994  
 Email: sales@fms-sa.co.za

P.O. Box 5533  
 West Krugersdorp  
 1742

24 Carter Street  
 Delporton  
 Krugersdorp

## Straight Taper Interlocks KY Type Mat. SK2 ± 56~58 HRC

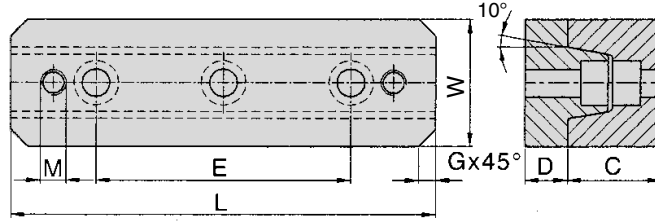

Order Code.	E	L	W	D	C	G	M
KY 50	36	50	25	8	17.5	5	M5
KY 100	60	100	30	10	22	4	M6
KY 150	100	150	40	13	25	5	M10

Order Code.	d1	d2	d3	K	A	B	Order Code.	d1	d2	d3	K	A	B
GP 10/14-26 14	10	14	15.8	3	26	14	GP 12/18-26 14	12	18	21.5	6	26	14
GP 10/14-36 14	10	14	15.8	3	36	14	GP 12/18-36 14	12	18	21.5	6	36	14
GP 10/14-46 14	10	14	15.8	3	46	14	GP 12/18-46 14	12	18	21.5	6	46	14
							GP 12/18-56 14	12	18	21.5	6	56	14

## Blow Mould Guide Pin Mat. 1.7131

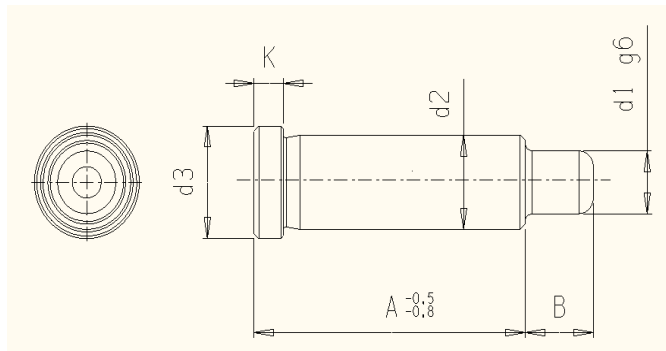
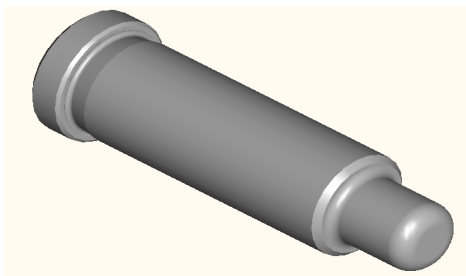

Order Code.	d1	d2	d3	K	A	B	Order Code.	d1	d2	d3	K	A	B
GP 10/14-26 14	10	14	15.8	3	26	14	GP 12/18-26 14	12	18	21.5	6	26	14
GP 10/14-36 14	10	14	15.8	3	36	14	GP 12/18-36 14	12	18	21.5	6	36	14
GP 10/14-46 14	10	14	15.8	3	46	14	GP 12/18-46 14	12	18	21.5	6	46	14
							GP 12/18-56 14	12	18	21.5	6	56	14