



# Form Mould Services cc.

Phone: (011)953-3947/59  
 Fax: (011)953-4994  
 Email: sales@fms-sa.co.za

P.O. Box 5533  
 West Krugersdorp  
 1742

24 Carter Street  
 Delporton  
 Krugersdorp

## Tubular Dowels Mat. 1.7131

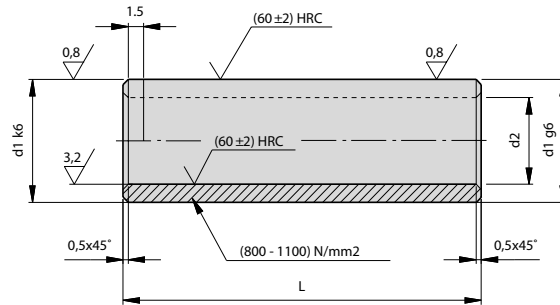

Order Code.	d1	d2	L	Order Code.	d1	d2	L
TD 24 x 50	17	24	50	TD 32 x 60	25	32	60
TD 24 x 60			60	TD 32 x 100			100
TD 24 x 76			76	TD 32 x 120			120
TD 24 x 86			86	TD 32 x 140			140
TD 24 x 96			96	TD 32 x 160			160
TD 28 x 60	21	28	60	TD 42 x 60	34	42	60
TD 28 x 80			80	TD 42 x 100			100
TD 28 x 100			100	TD 42 x 120			120
TD 28 x 120			120	TD 42 x 160			160
TD 28 x 140			140	TD 42 x 180			180

## Angle Pins Mat. 1.7131

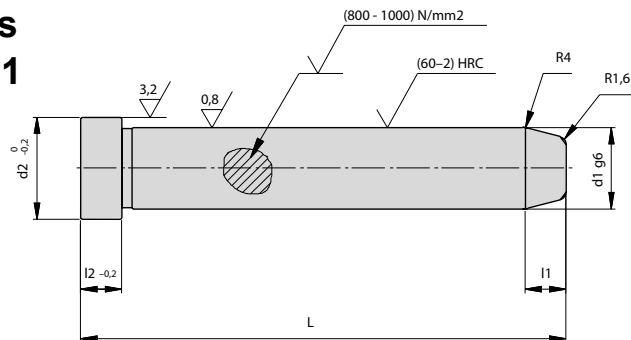

Order Code.	d1	d2	l1	l2	L	Order Code.	d1	d2	l1	l2	L
AP 10 x 60	10	12	4	3	60	AP 16 x 60	16	20	5	8	60
AP 10 x 80					80	AP 16 x 80					80
AP 10 x 100					100	AP 16 x 100					100
AP 10 x 120					120	AP 16 x 120					120
						AP 16 x 140					140
AP 12 x 60	12	16	5	6	60	AP 16 x 160					160
AP 12 x 80					80	AP 16 x 180					180
AP 12 x 100					100	AP 16 x 200					200
AP 12 x 120					120	AP 16 X 220					220
AP 12 x 140					140						
AP 12 x 160					160	AP 20 x 100	20	24	7	8	100
						AP 20 x 120					120
AP 14 x 60	14	18	5	8	60	AP 20 x 140					140
AP 14 x 80					80	AP 20 x 160					160
AP 14 x 100					100	AP 20 x 180					180
AP 14 x 120					120	AP 20 x 200					200
AP 14 x 140					140	AP 20 x 220					220
AP 14 x 160					160						
AP 14 x 180					180	AP 24 x 100	24	28	7	8	100
						AP 24 x 120					120
						AP 24 x 140					140
						AP 24 x 160					160
						AP 24 x 260					260